

INTRODUCTION

INS Global is a communication engineering company that develops innovative products for the life-safety industry and BMS (Building Management Systems).

INS Global products are designed to support a diverse range of protocols with a modular interface structure allowing for the rapid introduction of new protocols and emerging technologies.

ADVANTAGES

- Detailed event information from fire panels and BMS devices
- Supports multiple protocols
- Global notification of events via smartphone notification, SMS or email to selected users
- Wifi/Ethernet/4G/LTE cloud link
- Configurable via a web browser

PRODUCTS

IRIS200 (CLOUD CONNECTION OPTIONAL)

Site Gateway for ICNS Event Routing

The IRIS200 is an industrial cloud event interface and display with live event notification via SMS and push notification.

Features

- Bluetooth Interface to ICN001/2
- RS-232 & Ethernet to FAP
- WiFi Interface to Router (2.4GHz & 5GHz)
- High Gain External WiFi Antennas
- Ethernet Interface to LAN
- HDMI & RGB Display Interface
- Dual location Event Archiving
- Smartphone App Notification
- SMS & Email Notification Supported
- Basic Fire, Fault, Network & I/O Event display supported with Graphics
- Multiple Protocols Supported

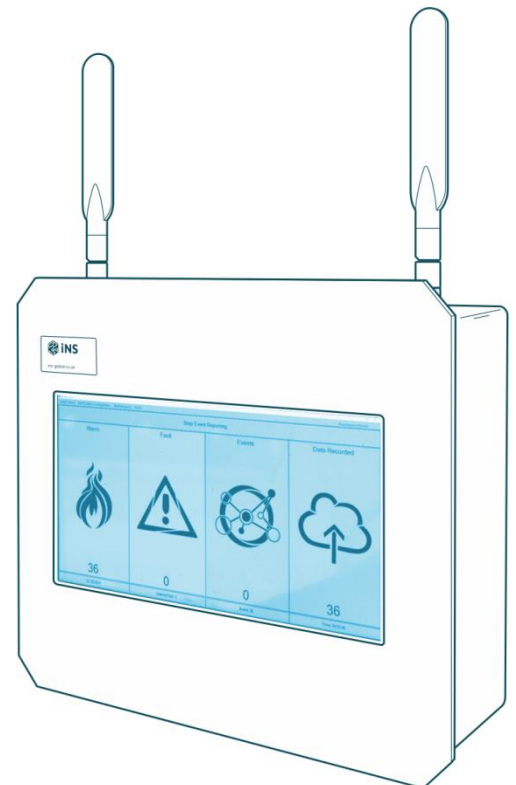

IRIS-DU50 DISPLAY UNIT

A remote display unit for the IRIS-X Monitoring and Notification System

Features

- LAN to IRIS-X communication interface
- HDMI and RGB display interface
- Multiple protocols supported
- All IRIS-X functionalities supported with the exception of notification and cloud repository features



CEVIEW

The ICNS CEVIEW Application monitors events that occur remotely. Users can generate real time incident reports and bespoke reports for the purpose of maintenance and audit.

Event Monitoring

All events occurring on the fire panel are displayed on the Live Event view and can be downloaded as a report for a specific time period.

Fault Reporting

The web application displays if a site is experiencing a fault and any network errors.

Live Monitoring

The web application is connected to a database and is being constantly updated from the fire panel for a live view.

Features

- Remote monitoring. User can see all live events such as Fires, Faults, I/O and Network Errors
- Live event data, straight from the installed fire panel
- Incident report generation
- Tailored reporting for maintenance and auditive purposes

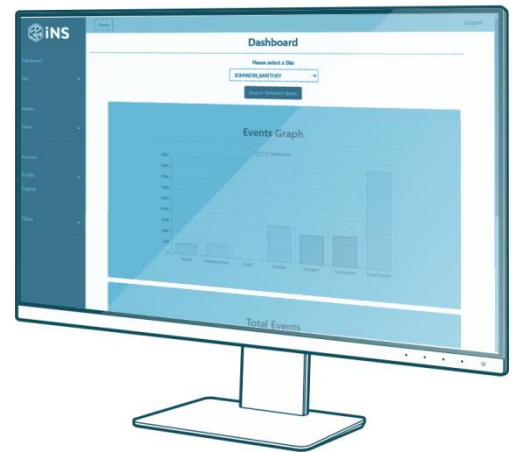

1. EVENT DISPLAY PANEL APPLICATION, USING VLAN

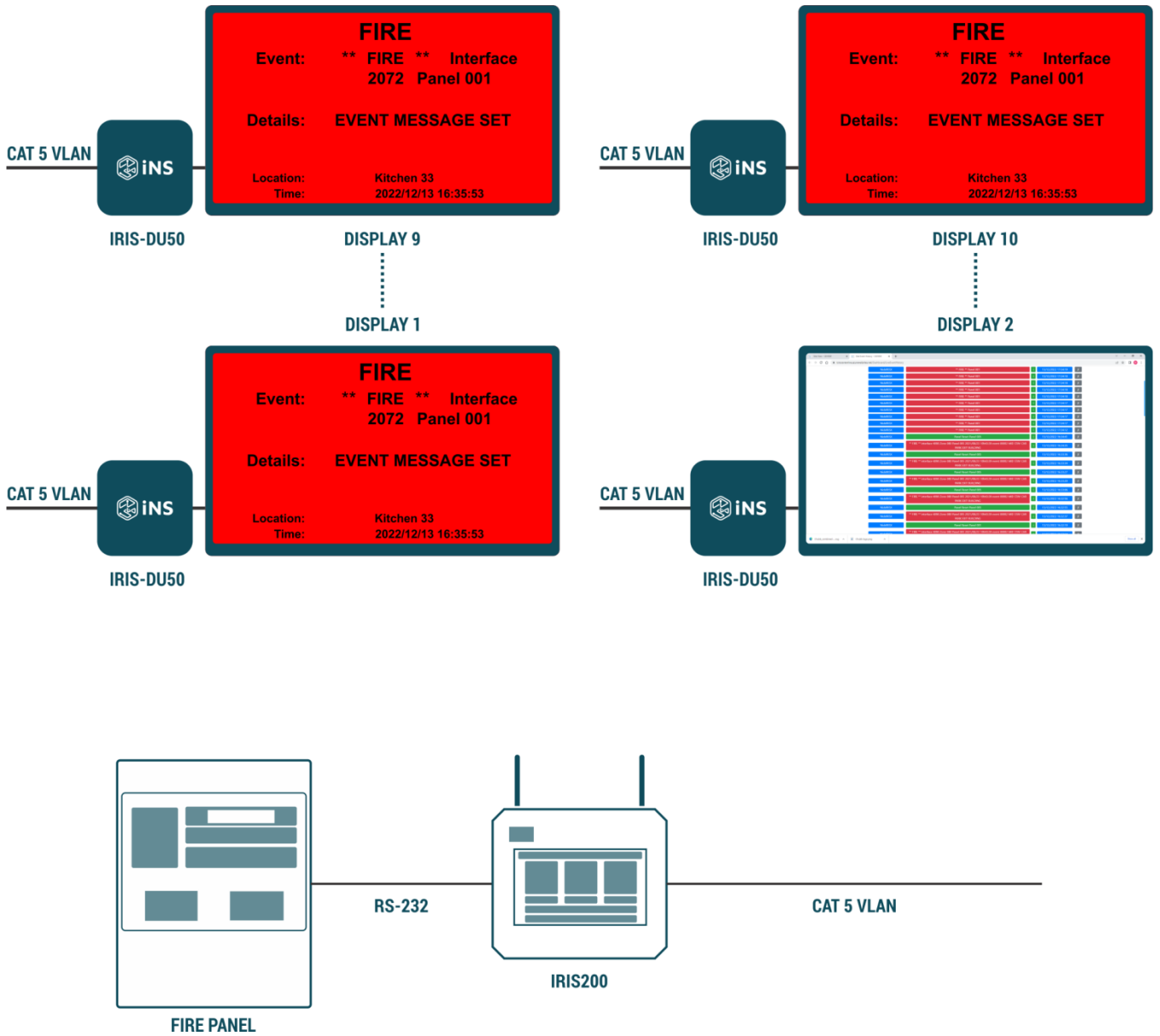

FIGURE 1: EVENT DISPLAY PANEL APPLICATION, USING VLAN

2. EVENT DISPLAY PANEL APPLICATION, USING VLAN, WITH REMOTE MONITORING NOTIFICATION AND REPORT GENERATION WITH LOCAL EVENT DISPLAY, REDUNDANT DATABASE AND LOCAL REPOSITORY

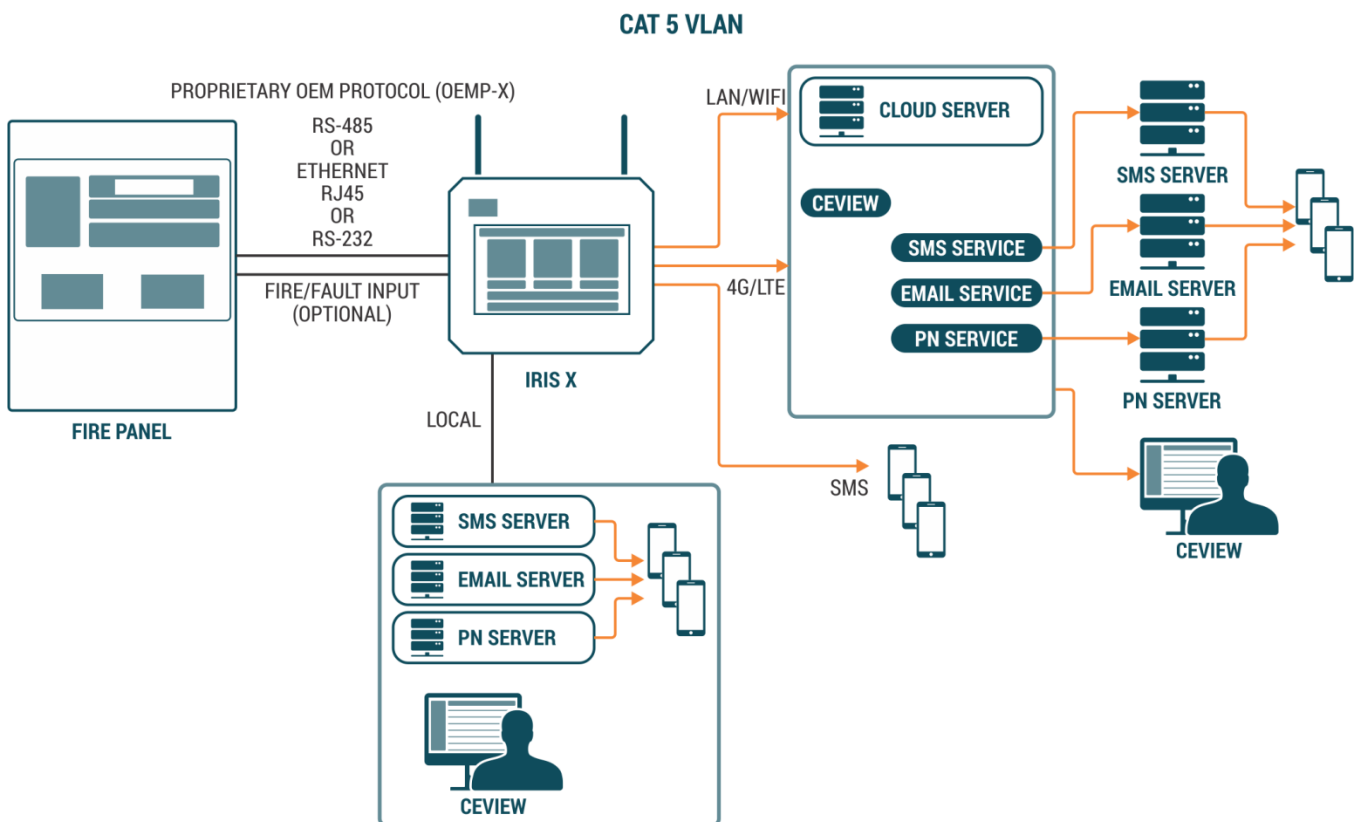
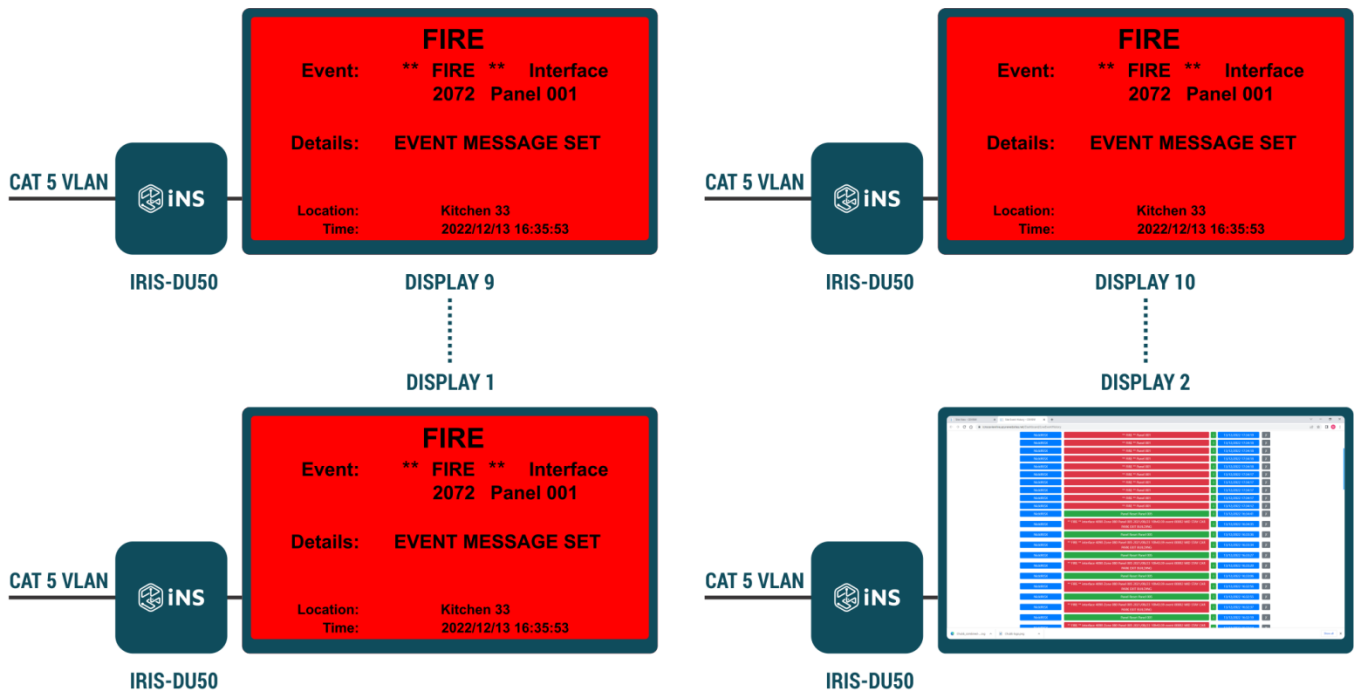

FIGURE 2: EVENT DISPLAY PANEL APPLICATION, USING VLAN, WITH REMOTE MONITORING NOTIFICATION AND REPORT GENERATION WITH LOCAL EVENT DISPLAY, REDUNDANT DATABASE AND LOCAL REPOSITORY

3. EVENT DISPLAY PANEL APPLICATION, USING RS-485

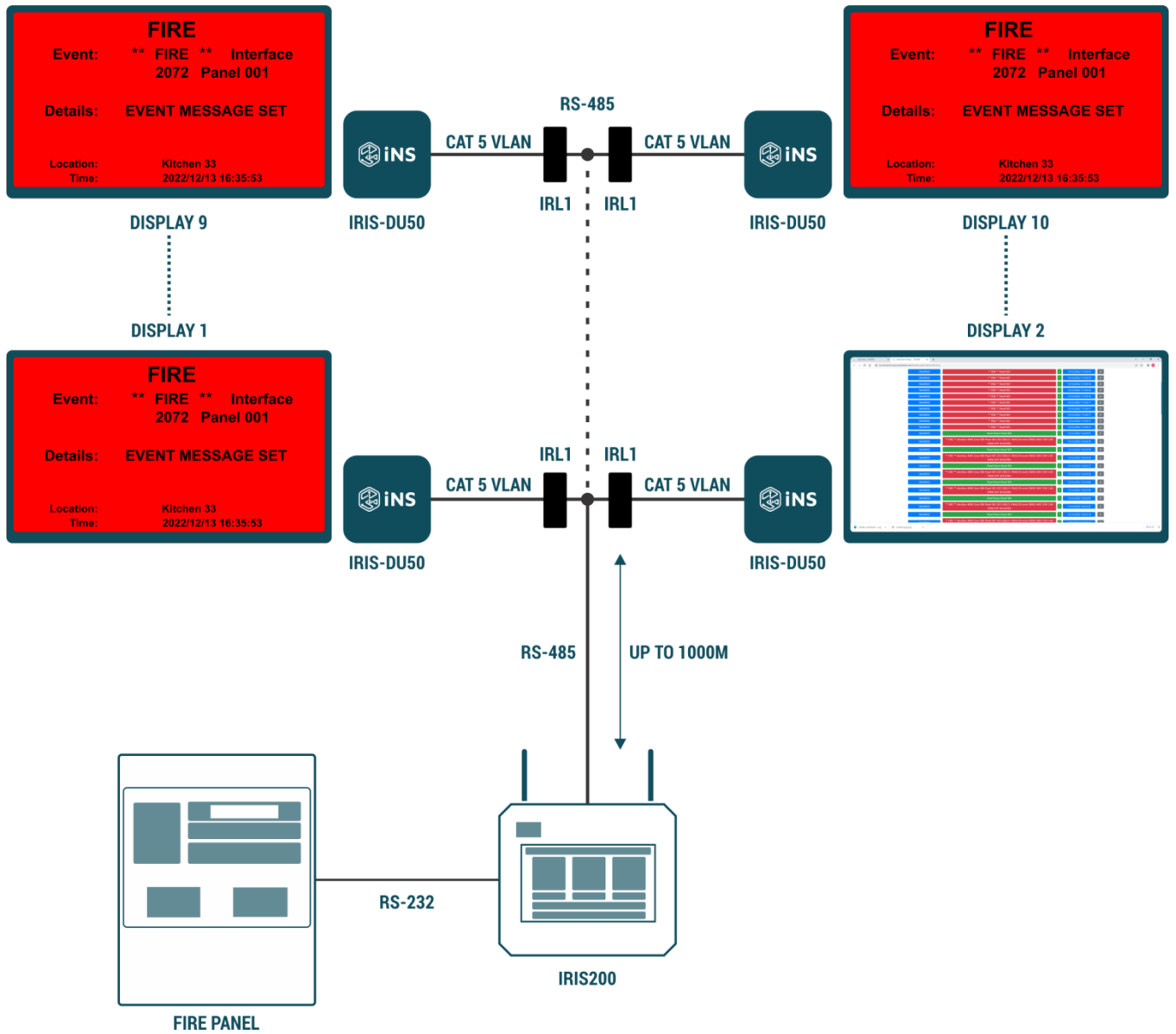

FIGURE 3: EVENT DISPLAY PANEL APPLICATION, USING RS-485

4. EVENT DISPLAY PANEL APPLICATION, USING OPTIC FIBRE

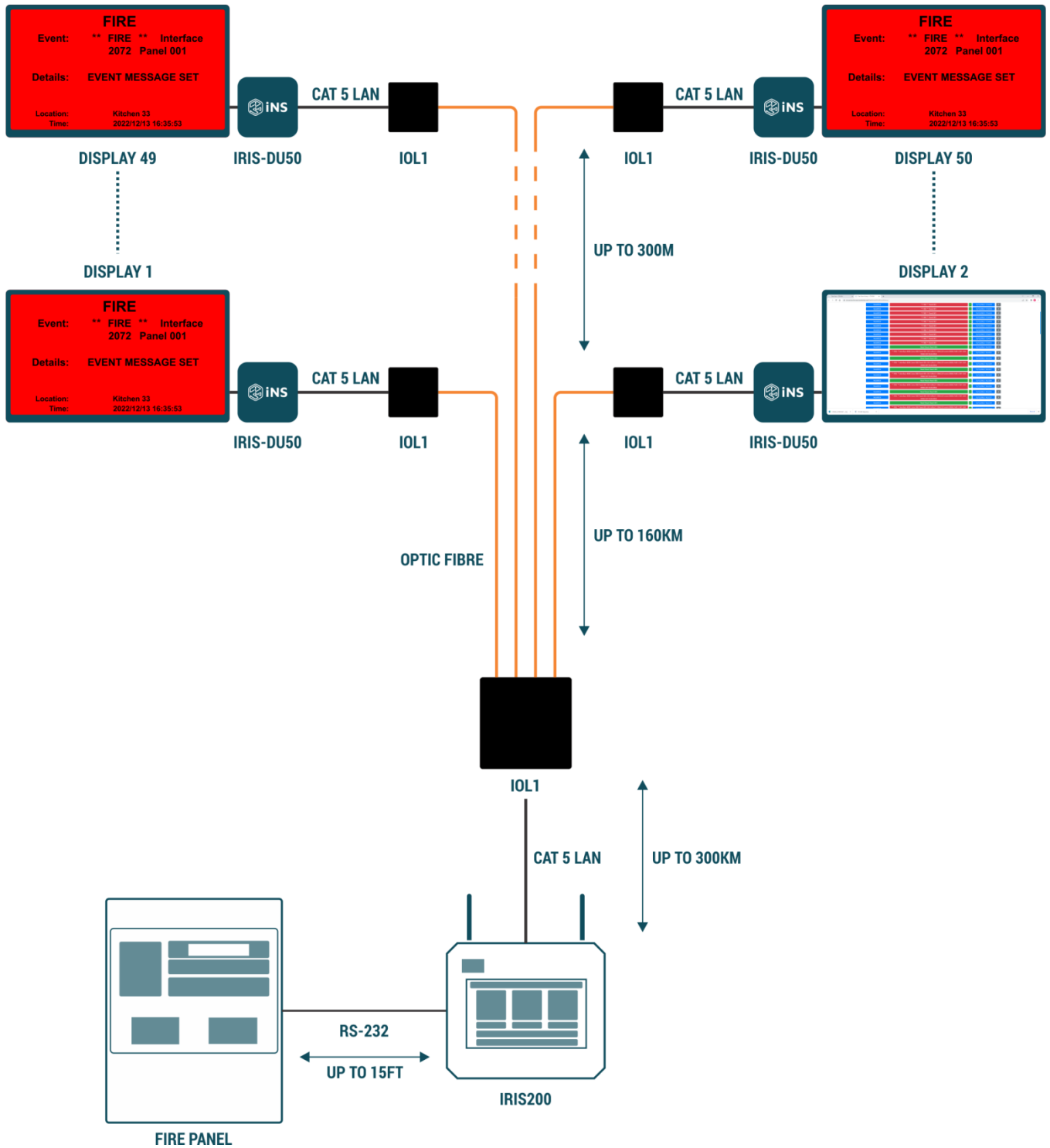

FIGURE 4: EVENT DISPLAY PANEL APPLICATION, USING OPTIC FIBRE

SPECIFICATIONS

IRIS-DU50

DIMENSIONS	
Dimensions	17.09 x 11.99 x 5.59 cm
Weight	381g
SYSTEM	
Processor	Intel Atom Z8350, Model Wintel Pro
Form Factor	Small form factor
Processor Speed	1.92 GHz
Processor Count	4
RAM Size	2GB
Memory Technology	LPDDR3
Computer Memory Type	DDR3 SDRAM
Memory Clock Speed	1.92 GHz
Hard Drive Size	32 GB
Hard Disk Description	eMMC
Graphics Chipset Brand	Intel
Graphics Card Interface	Integrated
Connectivity Type	Bluetooth, Wi-Fi
Wireless Type	802.11bgn
Number of USB 2.0 Ports	2
Hardware Platform	Windows
Operating System	Windows 10 Pro
CPU	Intel Atom X5-Z8350 Quad-Core
GPU	Intel Gen 9
Process Technology	14nm
Power Consumption	2W
Caching	2MB
RAM	2GB (LPDDR3)
Internal Memory	32GB (eMMC)
External Memory (SD Card)	Support up to 128GB (not included)
Bluetooth	Bluetooth 4.0
Power adapter	5V
Wi-Fi	802.11 a/b/g/n/ac
PORTS	
	3.5mm Audio DC IN HDMI LAN RJ45 (1000 Mbps) USB 2.0 USB 3.0 SD Card
INCLUDED	
	W8 Pro Mini PC Power Adapter (UK plug as standard - also available with US and EU when requested) HDMI Cable User Manual

