

INTRODUCTION

A fast and simple way to introduce a reliable communications link between two fire panels, using the existing LAN infrastructure.

The INS008 and INS009 pairs can be installed in places where there is difficulty in installing new communications cables.

INS009 provides a bi-directional Input/Output interface for relaying system states to the INS008 Ethernet module, linked via an RS-485 interface. The INS009-3 supports two signal inputs and three relay outputs.

The two inputs can typically be used to transfer the status of 'Fault' and 'Fire' contacts from a fire panel across a monitored link between two INS008 modules. All relay outputs are driven by signal states presented by the INS008 module. When used with the INS008 modules, the INS009 activates an external relay contact, based on the state of the monitored communication link between local and remote paired INS008 modules.

The link can consist of LAN/Ethernet cable, optic fibre, WIFI or a 4G/LTE dual SIM VPN link

The module is housed in a DIN rail mountable enclosure with LED status indication visible on the front fascia of the module.

ADVANTAGES

- Critical path monitored link
- Bi-directional fault, fire and remote relay monitoring
- Pre-configured, redundant power supply
- Battery-backed and ready to install (in IP67 enclosure)
- Visual display
- Link is constantly monitored
- Adjustable link latency
- Support for multi-mode, up to 2km
- Support for single mode, up to 160km
- WIFI up to 183m/600ft
- Dual SIM 4G/LTE redundant link with auto switchover

PRODUCTS

- INS008
- INS009
- Ethernet to Optic Fibre Medium Converter, with Optic Fibre Transceivers
 - Multimode 550m
 - Single mode 10km, 20km, 40km, 80km and 160km
- AC1200 WIFI MU-MIMO Gigabit Indoor/Outdoor
- Dual SIM 4G/LTE Cat 4 Router
- Redundant Power Supply
- 48-hour standby battery

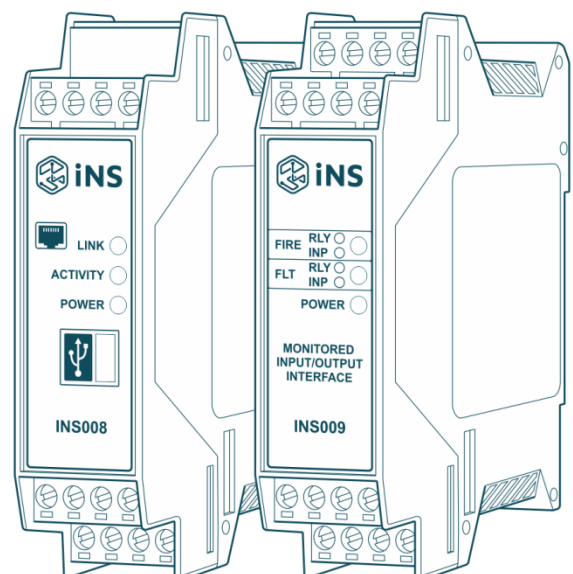

WIRING DIAGRAMS

INS009	
A1	Relay Output – Normally Open [Remote Fire Activation]
A2	Relay Output – Normally Open [Remote Fire Activation]
A3	Relay Output – Normally Open [Remote Fault Activation]
A4	Relay Output – Normally Open [Remote Fault Activation]
B1	Input – Normally Open [Local Fire Activation]
B2	Input Common [Local Fire Activation]
B3	Input – Normally Open [Local Fault Activation]
B4	Input Common [Local Fault Activation]
C1	In / Out / + line RS-485
C2	In / Out / - line RS-485
C3	Relay Output (Link Fault)
C4	Relay Output (Link Fault)
D1	+18 to 36 Volt DC – Input Power
D2	0 Volt – Input Power
D3	No Connection
D4	Earth Connection – Discharge connection

INS008	
A1	Ethernet Interface
B1	Earth Connection
B2	Screen/Shield RS-485
B3	In / Out / + line RS-485
B4	In / Out / - line RS-485
C1	RS-232 Shield [Optional - Not included on this part]
C2	RS-232 RX [IN] [Optional - Not included on this part]
C3	RS-232 TX [OUT] [Optional - Not included on this part]
C4	Earth Connection [Optional - Not included on this part]
D1	+18 to 36 Volt DC – Input Power
D2	0 Volt – Input Power
D3	No Connection
D4	Earth Connection – Discharge connection

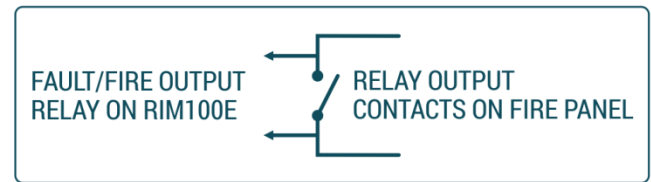
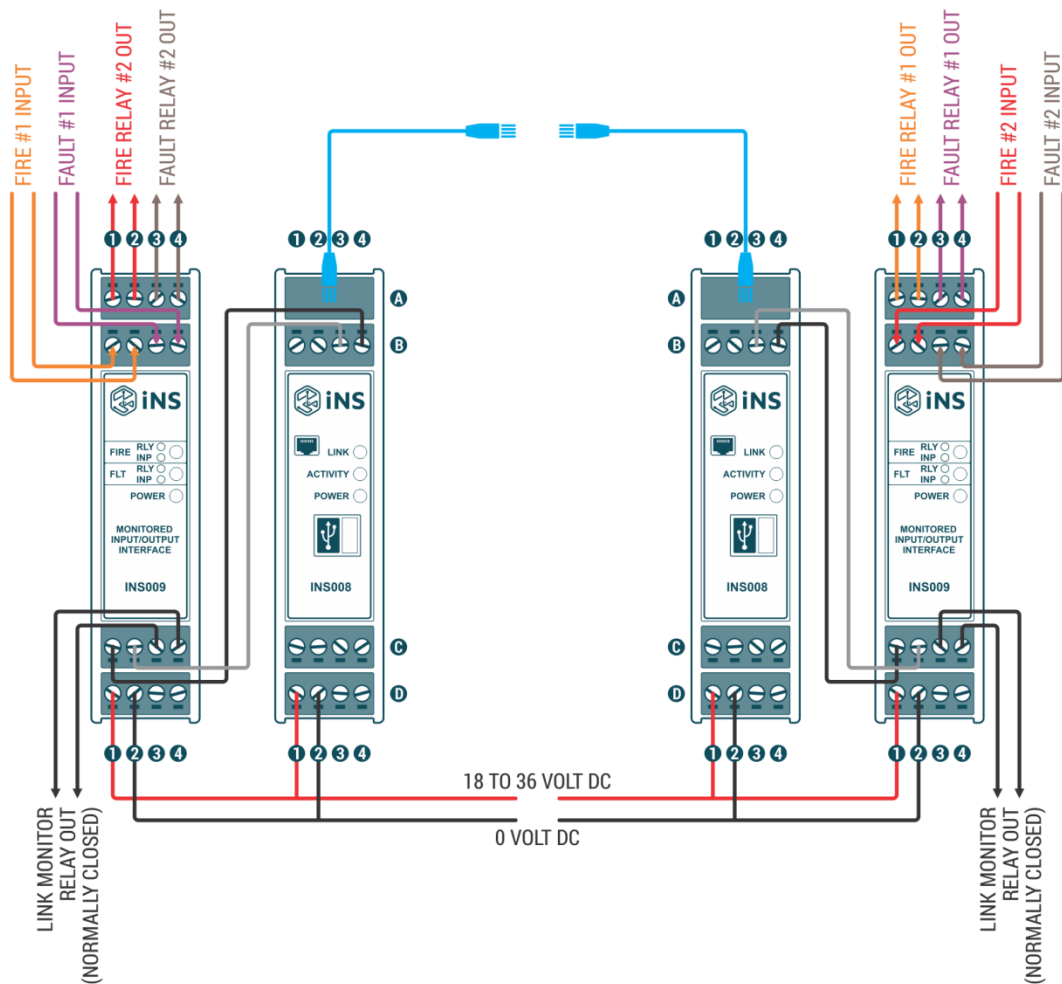

FIGURE 1: MONITORED LAN LINK USING INS008 AND INS009

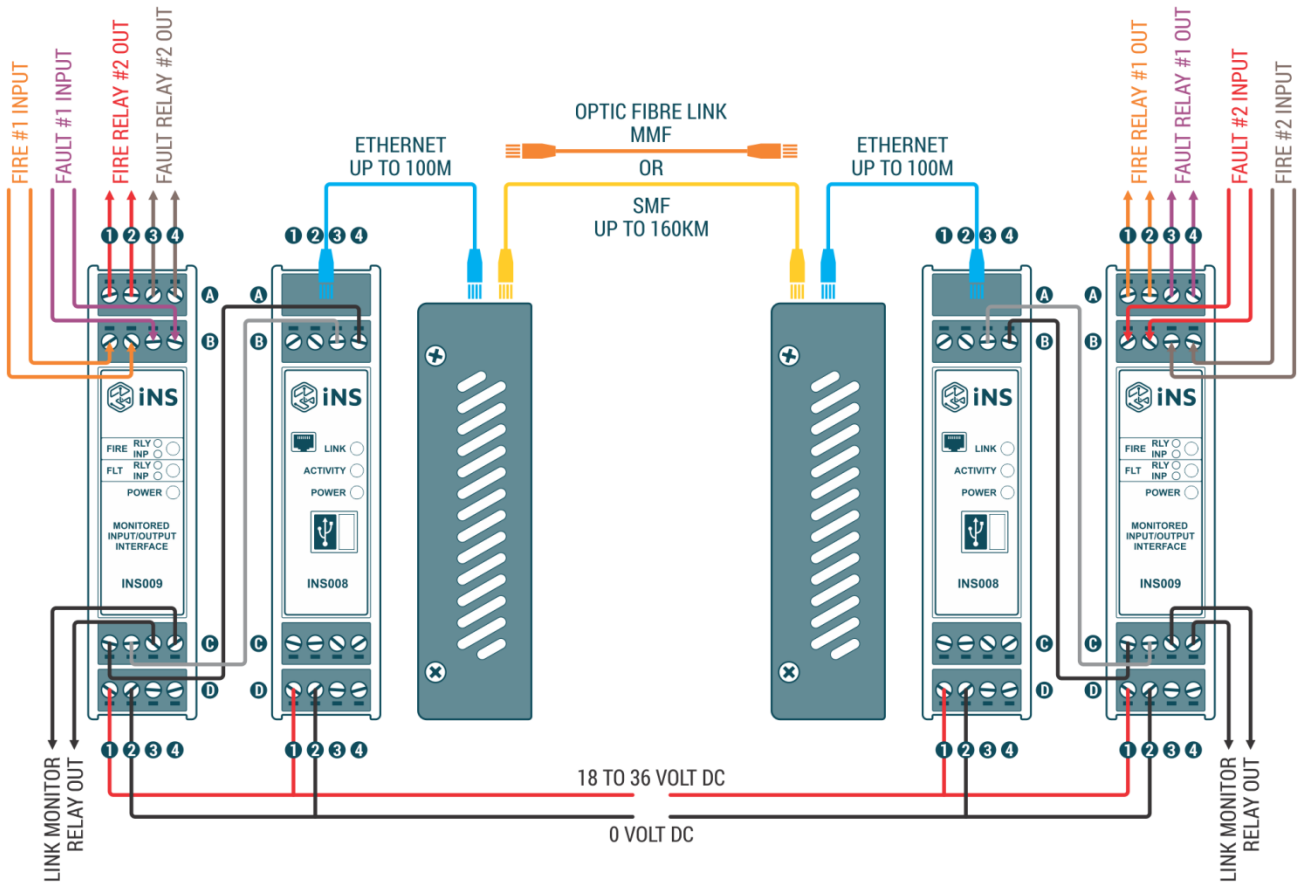

FIGURE 2: MONITORED FAULT AND FIRE I/O LINK VIA OPTIC FIBRE

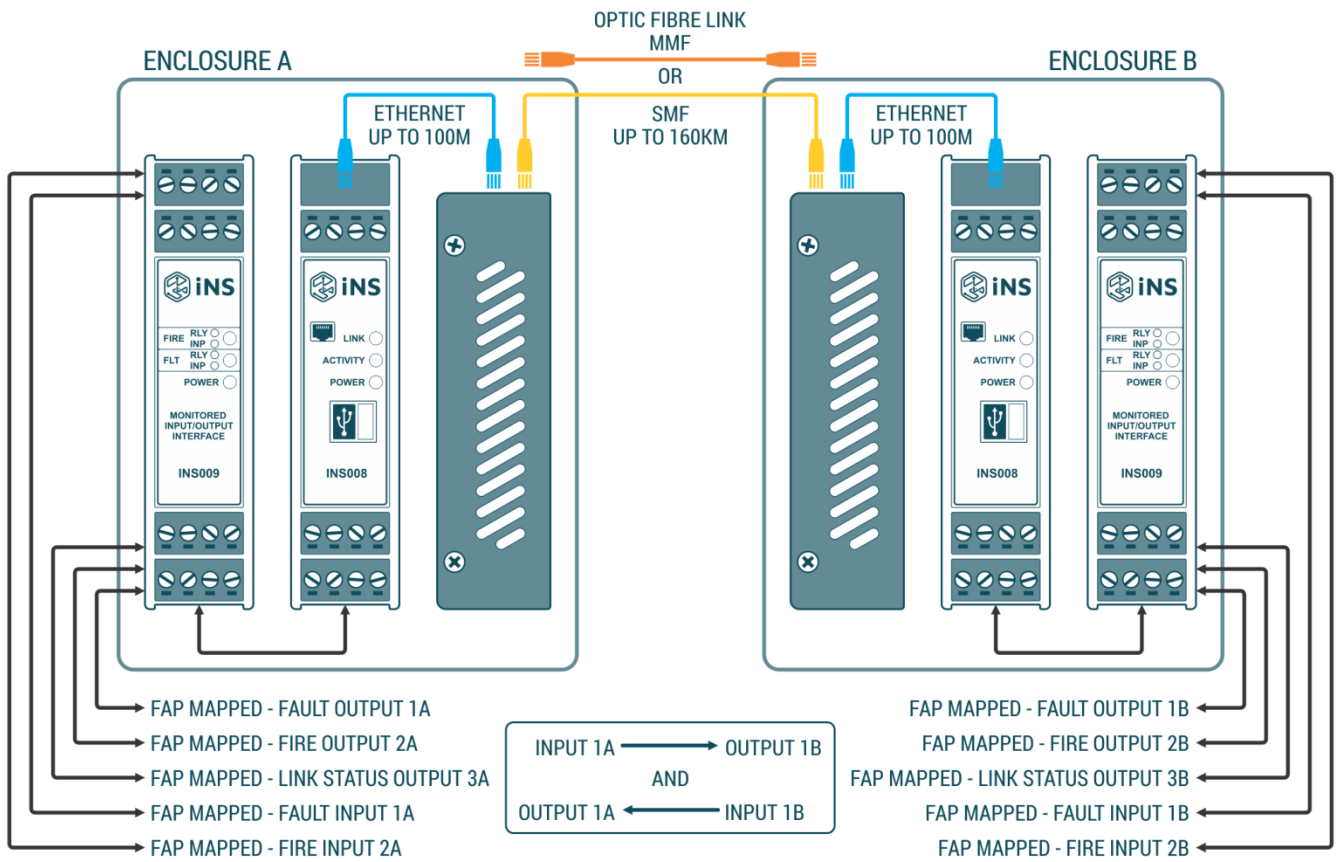

FIGURE 3: FUNCTIONAL DIAGRAM

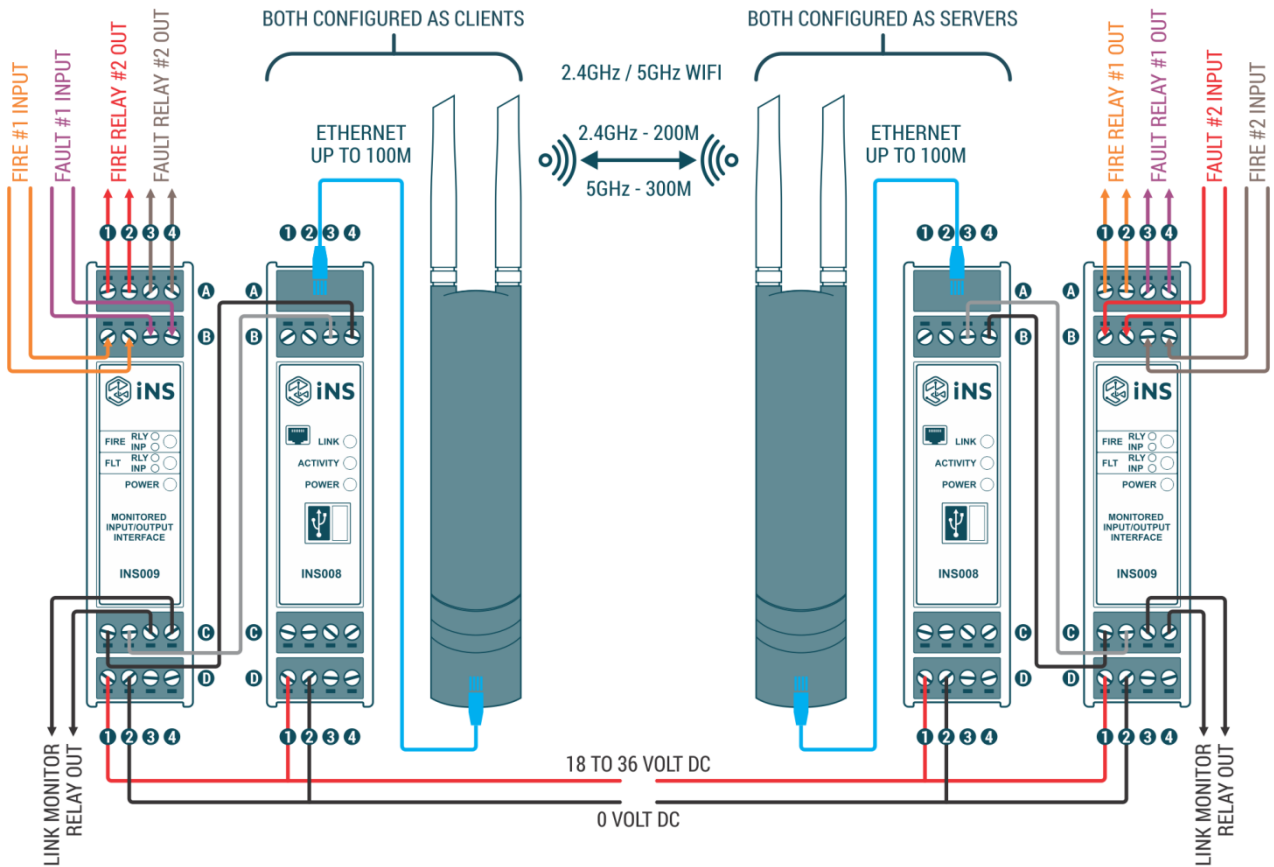

FIGURE 4: MONITORED FAULT AND FIRE I/O LINK VIA WIFI

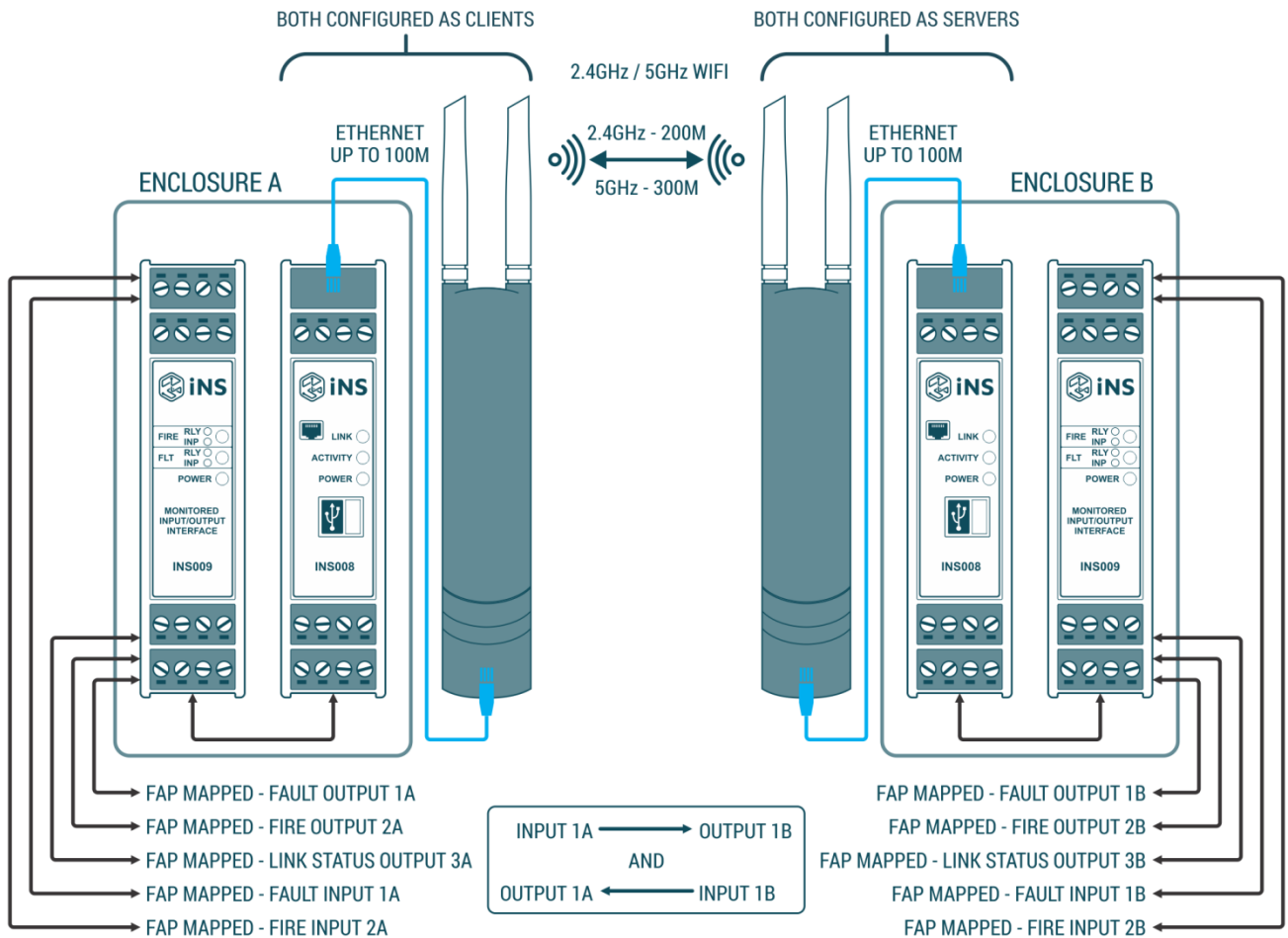

FIGURE 5: FUNCTIONAL DIAGRAM

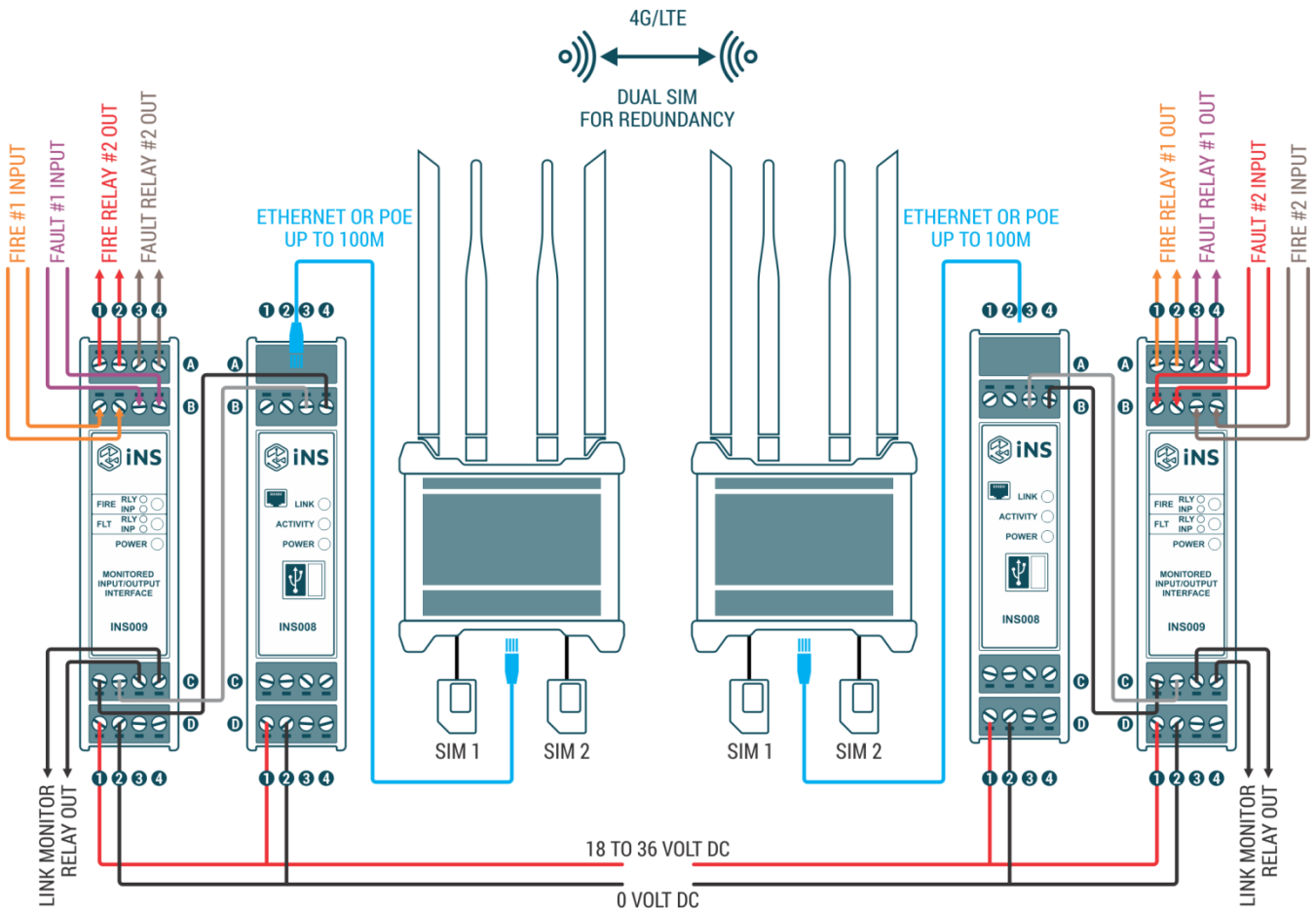

FIGURE 6: MONITORED FAULT AND FIRE I/O LINK VIA A REDUNDANT 4G/LTE VPN

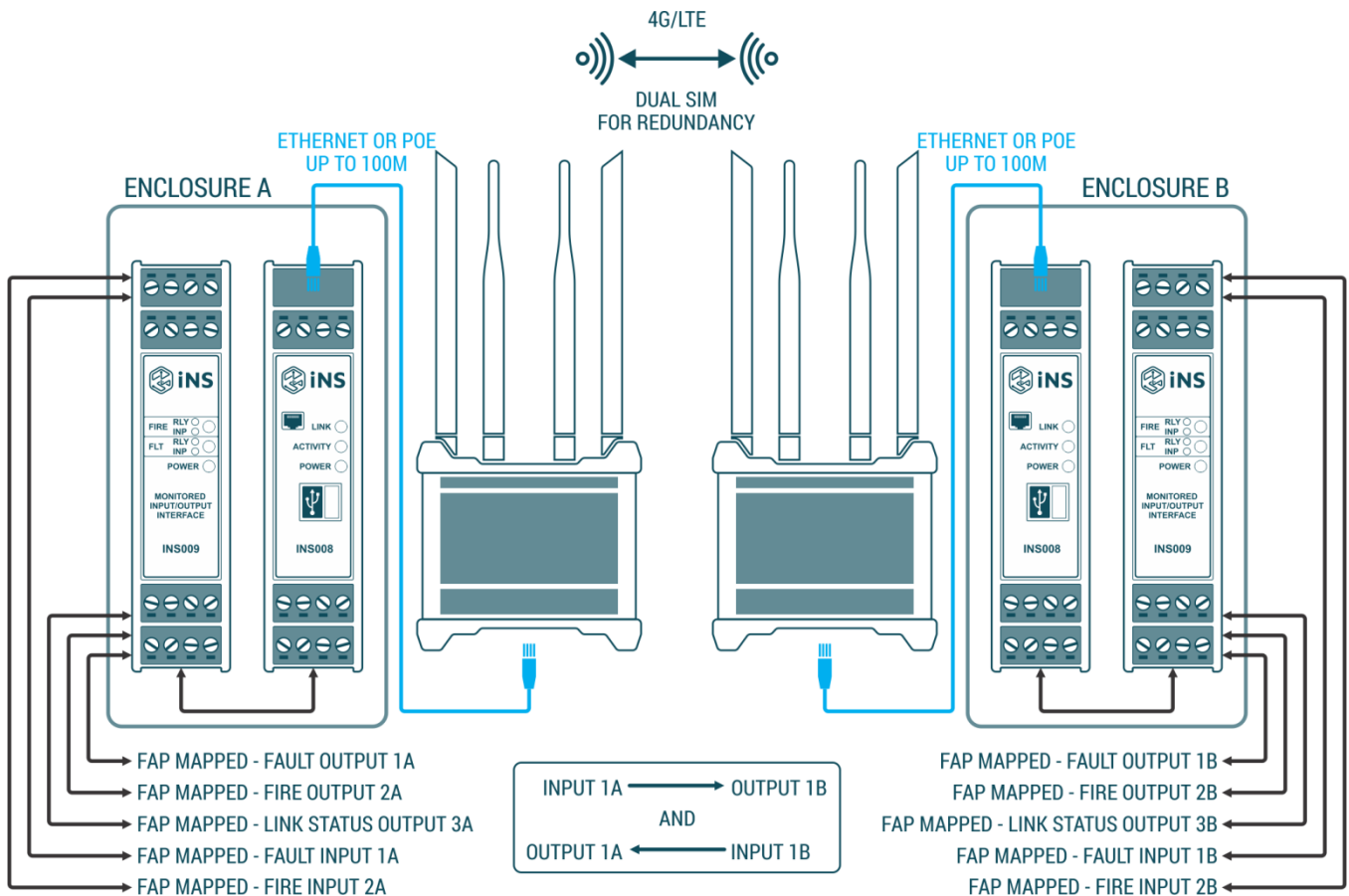

FIGURE 7: FUNCTIONAL DIAGRAM

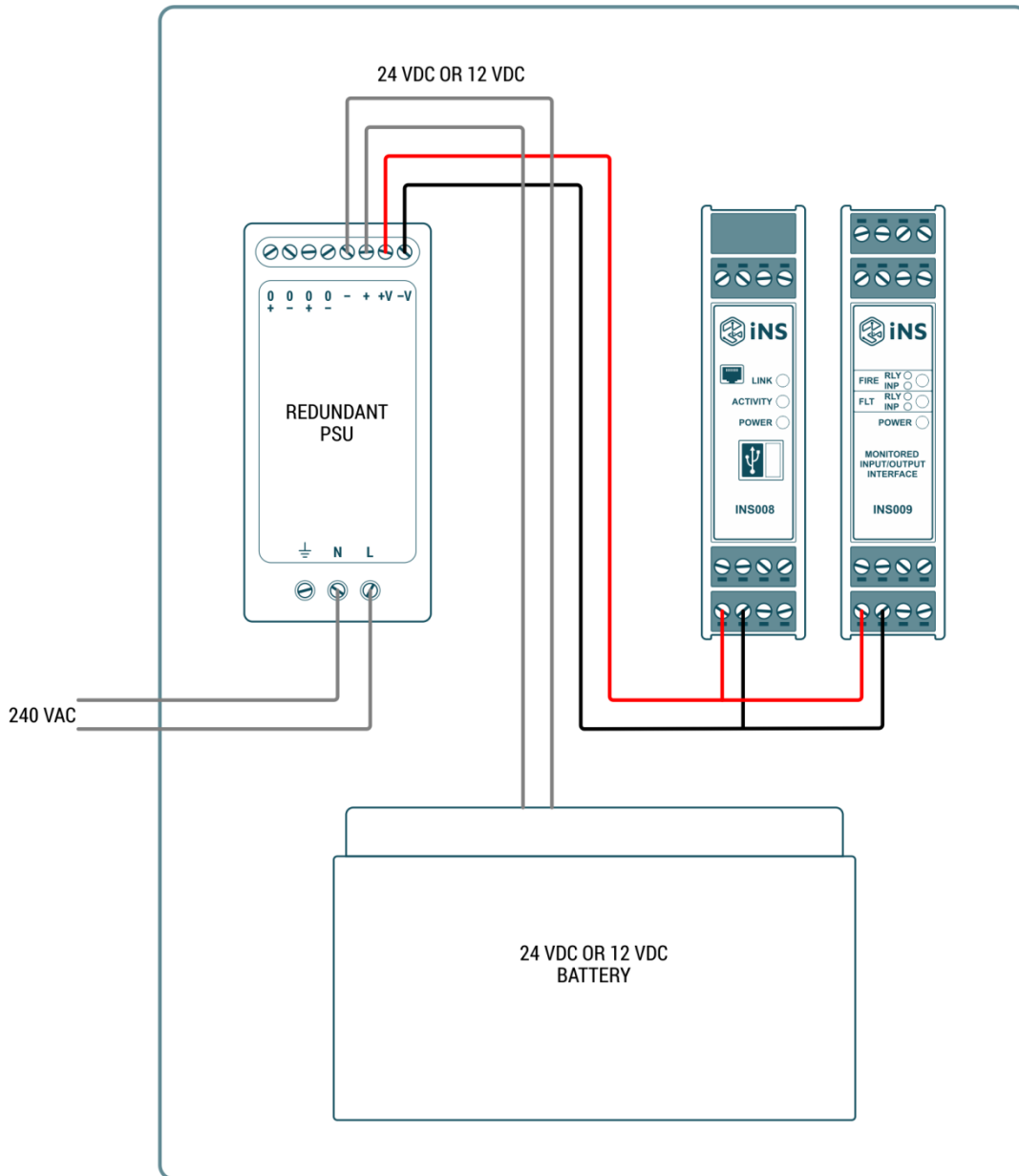

FIGURE 8: REDUNDANT POWER SUPPLY CONFIGURATION

SPECIFICATIONS

INS008

ETHERNET INTERFACE A	
Net port	10/100 Mbps
Connection	RJ45
RS-485 PORT B	
Electrical specification	RS-485
Data rate	19.2 kbit/s
Data format	8 Data bits; Even parity; 1 Stop bit (RS-485)
Connection	Detachable screw terminal
Connector size	0.2 – 2.5 mm ² (AWG 24-12)
Transmission range	In accordance with EIA RS-485 ≤ 1200 m, depending on data rate and cable type
RS-485 Termination settings	IN/OUT Switchable termination (jumper selectable)
RS-485 Failsafe setting	Failsafe biasing 820 Ω (jumper selectable)
Protection	Installation Fault Tolerant (up to ± 44 V)
RS-232 PORT C	
[Optional - Not assembled in this Part]	
Electrical specification	RS-232
Data rate	4.8 kbit/s – 312 kbit/s (as per selection in table)
Data format	7 or 8 Data bits; Odd, Even or None parity; 1 or 2 Stop bits (RS-232)
Connection	Detachable screw terminal
Connector size	0.2 – 2.5 mm ² (AWG 24-12)
Transmission range	In accordance with EIA RS-232 ≤ 12ft, depending on data rate and cable type
POWER TERMINALS D	
Rated voltage	18 to 36 VDC
Operating voltage	18 to 42 VDC
Rated current	100 mA @ 24 VDC
Rated frequency	DC
Connection	Detachable screw terminal
Connection size	0.2 – 2.5 mm ² (AWG 24-12)
USB	
Electrical specification	USB version 2.0
USB version 2.0	Full speed device mode as per USB 2.0 specification
Data format	As per USB specification
Connector type	USB micro B (device) - cable type micro B required
Implementation mode	Slave
Protection	Transient voltage protection

INS009

RS-485 PORT C	
Electrical specification	RS-485
Data rate	19.2 kbit/s
Data format	8 Data bits; Even parity; 1 Stop bit (RS-485)
Connection	Detachable screw terminal
Connector size	0.2 – 2.5 mm ² (AWG 24-12)
Transmission range	In accordance with EIA RS-485 ≤ 1200 m, depending on data rate and cable type
RS-485 Termination settings	IN/OUT Switchable termination (jumper selectable)
RS-485 Failsafe setting	Failsafe biasing 820 Ω (jumper selectable)
Protection	Installation Fault Tolerant (up to ± 44 V)
POWER TERMINALS D	
Rated voltage	18 to 36 VDC
Operating voltage	18 to 42 VDC
Rated current	50 mA @ 24 VDC
Rated frequency	DC
Connection	Detachable screw terminal
Connection size	0.2 – 2.5 mm ² (AWG 24-12)

WIFI

HARDWARE FEATURES	
Interface	Gigabit Ethernet (RJ-45) Ports (Support 802.3af PoE and Passive PoE)
Button	Reset
Power Supply	802.3af PoE and 24 Passive PoE (PoE Adapter Included with 1 LAN Port + 1 LAN PoE Port)
Power Consumption	10.5W
Dimensions (W x D x H)	8.5 × 1.8 × 1.1 in. (215 × 46 × 27 mm)
Antenna	2.4GHz: 2 * 3dBi, 5GHz: 2 * 4dB
Weatherproof Enclosure	IP65
Mounting	Pole/Wall Mounting (Kits included)
Hardware Watch Dog	Yes
WIRELESS FEATURES	
Wireless Standards	IEEE 802.11a/b/g/n/ac
Frequency	2.4GHz, 5GHz
Wireless Security	Wireless Mac Address Filtering Wireless Isolation Between Clients SSID to VLAN Mapping
ENVIRONMENTAL	
Operating Temperature	-30°C~70°C (-22°F~158°F)
Storage Temperature	-40°C~70°C (-40°F~158°F)
Operating Humidity	10%~90% non-condensing
Storage Humidity	5%~90% non-condensing
CERTIFICATION	
CE, FCC, RoHS	
PACKAGE CONTENTS	
AC1200 Wireless MU-MIMO Gigabit Indoor/Outdoor	
Access Point	
EAP225-Outdoor	
Power Adapter	
Mounting Kits	
Installation Guide	

RUT950 WIFI 4 3G/4G LTE CAT 4 ROUTER

MOBILE	
Mobile module	4G (LTE) Cat 4 – Up to 150 Mbps 3G – Up to 42 Mbps 2G – Up to 236.8 kbps
SIM switch	Two (2) SIM cards (not included) Auto-switch cases: <ul style="list-style-type: none"> • Weak signal • Data limit • SMS limit • Roaming • No network • Network denied • Data connection fail • SIM idle protection
Status	SINR RSRP RSRQ Bytes sent/received
Bridge	Direct connection (bridge) between mobile ISP and device on LAN
SMS	SMS status SMS configuration Send/read SMS via HTTP POST/GET EMAIL to SMS SMS to EMAIL SMS to HTTP SMS to SMS Scheduled SMS SMS autoreply SMPP

Black/White list	Operator black/white list
Multiple PDN (optional)	Possibility to use different PDNs for multiple network access and services
Band management	Band lock Used band status display
WIRELESS	
Wireless mode	IEEE 802.11b/g/n, Access Point (AP), Station (STA)
WiFi	WPA2-Enterprise (with external/internal Radius server), WPA2-PSK, WPA-PSK, WEP, MAC Filter
WiFi security	WPA2-Enterprise - PEAP, TLS, TTLS. AES-CCMP, TKIP, Auto Cipher modes. Client separation
SSID	SSID stealth mode and access control based on MAC address
WiFi users	Up to 100 simultaneous connections
Hotspot	Captive portal (Hotspot), internal/external Radius server, built in customisable landing page
ETHERNET	
WAN	1 x WAN port (can be configured to LAN) 10/100 Mbps, comply IEEE 802.3, IEEE 802.3u standards, supports auto MDI/MDIX
LAN	3 x LAN ports, 10/100 Mbps, comply IEEE 802.3, IEEE 802.3u standards, supports auto MDI/MDIX
NETWORK	
Routing	Static routing, Dynamic routing (BGP, OSPF v2, RIP v1/v2)
Network protocols	TCP, UDP, IPv4, IPv6, ICMP, NTP, DNS, HTTP, HTTPS, FTP, SMTP, SSL v3, TLS, ARP, VRRP, PPP, PPPoE, UPNP, SSH, DHCP, Telnet, SNMP, MQTT, Wake On Lan (WOL)
VoIP passthrough support	H.323 and SIP-alg protocol NAT helpers, allowing proper routing of VoIP packets
Connection monitoring	Ping Reboot, Periodic Reboot, LCP and ICMP for link inspection
Firewall	Port forward, traffic rules, custom rules
DHCP	Static and dynamic IP allocation, DHCP Relay
QoS	Traffic priority queuing by source/destination, service, protocol or port, traffic priority queuing by source/destination, service, protocol or port, WMM, 802.11e
DDNS	Supported >25 service providers, others can be configured manually
Network backup	VRRP, Mobile, Wired and WiFi WAN options, each of which can be used as backup, using automatic Failover
Load balancing	Balance your internet traffic over multiple WAN connections
SECURITY	
Authentication	Pre-shared key, digital certificates, X.509 certificates
Firewall	Pre-configured firewall rules can be enabled via web-ui, unlimited firewall configuration via CLI; DMZ; NAT; NAT-T
Attack prevention	DDOS prevention (SYN flood protection, SSH attack prevention, HTTP/HTTPS attack prevention), port scan prevention (SYN-FIN, SYN-RST, X-mas, NULL flags, FIN scan attacks)
WiFi security	WPA2-Enterprise - PEAP, EAP-TLS, TLS, TTLS. AES-CCMP, TKIP, Auto Cipher modes. Client separation
VLAN	Port based and tag based VLAN separation
Mobile quota control	Set up custom data limits for both SIM cards
WEB filter	Blacklist for blocking out unwanted websites, whitelist for specifying allowed sites only
Access control	Flexible access control of TCP, UDP, ICMP packets, MAC address filter
VPN	
OpenVPN	Multiple clients and server can be running simultaneously, 12 encryption methods
OpenVPN Encryption	DES-CBC, RC2-CBC, DES-EDE-CBC, DES-EDE3-CBC, DESX-CBC, BF-CBC, RC2-40-CBC, CAST5-CBC, RC2-64-CBC, AES-128-CBC, AES-192-CBC, AES-256-CBC
IPsec	IKEv1, IKEv2, supports up to 4 x VPN IPsec tunnels (instances), with 5 encryption methods (DES, 3DES, AES128, AES192, AES256)
GRE	GRE tunnel
PPTP, L2TP	Client/Server services can run simultaneously
Stunnel	Proxy designed to add TLS encryption functionality to existing clients and servers without any changes in the programs' code
SSTP	SSTP client instance support
MODBUS	
Modbus TCP slave	ID range: 1-255
Modbus TCP master	Supported functions: 01, 02, 03, 04, 05, 06, 15, 16 Supported data formats: 8 bit: INT, UINT; 16 bit: INT, UINT (MSB or LSB first); 32 bit float (Big endian, Big endian with byte-swapped, Little endian, Little endian with byte-swapped)
MONITORING & MANAGEMENT	
WEB UI	HTTP/HTTPS, status, configuration, FW update, CLI, troubleshoot, event log, system log, kernel log
FOTA	Firmware update from sever, automatic notification
SSH	SSH (v1, v2)
SMS	SMS status, SMS configuration, send/read SMS via HTTP POST/GET
TR-069	OpenACS, EasyCwmp, ACSLite, tGem, LibreACS, GenieACS, FreeACS, LibCWMP, Friendly tech, AVSystem
MQTT	MQTT Broker, MQTT publisher
SNMP	SNMP (v1, v2, v3), SNMP trap
JSON-RPC	Management API over HTTP/HTTPS
MODBUS	MODBUS TCP status/control

RMS	Teltonika Remote Management System (RMS)
SYSTEM CHARACTERISTICS	
CPU	Atheros Wasp, MIPS 74Kc, 550 MHz
RAM	128 MB, DDR2
FLASH memory	16 MB SPI Flash
FIRMWARE / CONFIGURATION	
WEB UI	Update FW from file, check FW on server, configuration profiles, configuration backup, restore point
FOTA	Update FW/configuration from server
RMS	Update FW/configuration for multiple devices
Keep settings	Update FW without losing current configuration
FIRMWARE CUSTOMISATION	
Operating system	RutOS (OpenWrt based Linux OS)
Supported languages	Busybox shell, Lua, C, C++
Development tools	GPL package with build environment provided
INPUT/OUTPUT	
Input	1 x Digital Input
Output	1 x Digital Output
Events	SMS, EMAIL, RMS
POWER	
Connector	4 pin industrial DC power socket
Input voltage range	9 – 30 VDC (4 pin industrial socket), reverse polarity protection; surge protection >31 VDC 10us max
PoE (passive)	Passive PoE over spare pairs. Possibility to power up through LAN port, not compatible with IEEE802.3af and 802.3at standards
Power consumption	< 2 W idle, < 7 W Max
PHYSICAL INTERFACES (PORTS, LEDS, ANTENNAS, BUTTONS, SIM)	
Ethernet	4 x RJ45 ports, 10/100 Mbps
I/O's	1 x Digital Input, 1 x Digital Output on 4 pin power connector
Status LEDs	1 x Bi-colour connection status LED 5 x Connection strength LEDs 4 x LAN status LEDs 1 x Power LED
SIM	2 x SIM slots (Mini SIM - 2FF), 1.8 V/3 V, external SIM holders
Power	4 pin DC connector
Input/Output	2 x Programmable Inputs/Outputs
Antennas	2 x SMA for LTE 2 x RP-SMA for WiFi antenna connectors
Reset	Reset/restore to default button
PHYSICAL SPECIFICATION	
Casing material	Aluminium housing, plastic panels
Dimensions (W x H x D)	110 x 50 x 100 mm
Weight	235 g
Mounting options	DIN rail (can be mounted on two sides), flat surface placement
OPERATING ENVIRONMENT	
Operating temperature	-40°C to 75°C
Operating humidity	10% to 90% non-condensing
Ingress Protection Rating	IP30
MTBF	270,000 hrs
REGULATORY & TYPE APPROVALS	
Regulatory	CE/RED, FCC, IC/ISED, EAC, RCM, PTCRB, RoHS, WEEE, WiFi Alliance
EMI IMMUNITY	
Standards	Draft EN 301 489-1 V2.2.0, Draft EN 301 489-17 V3.2.0, Draft EN 301 489-19 V2.1.0, Draft EN 301 489-52 V1.1.0
ESD	EN61000-4-2:2009
RS	EN 61000-4-3:2006 + A1:2008 + A2:2010
EFT	EN 61000-4-4:2012
Surge immunity (AC Power Line)	EN 61000-4-5:2006
Surge immunity (Ethernet ports)	EN 61000-4-5:2014, clause 7.1 of ITU-T K21
Transient and surges	ISO 7632-2:2004
CS	EN 61000-4-6:2009
DIP	EN 61000-4-11:2004
RF	
Standards	EN 300 328 V2.1.1, EN 301 511 V12.5.1, EN 301 908-1 V11.1.1, EN 301 908-2 V11.1.1, EN 301 908-13 V11.1.1 AS/CA S042.1:2018, AS/ACIF S042.3:2005, AS/CA S042.4:2018, AS/NZS 4268:2017
SAFETY	
Standards	IEC 60950-1:2005 (Second Edition) + Am 1:2009 + Am 2:2013

	AS/NZS 60950.1:2015 EN 50665:2017, EN 62311:2008
ENVIRONMENTAL	
Ingress Protect	LST EN 60529:1999+A1+AC:2002
Vibration	Class guideline-DNVGL-CG-0339:2016 EN 60068-2-6:2008